

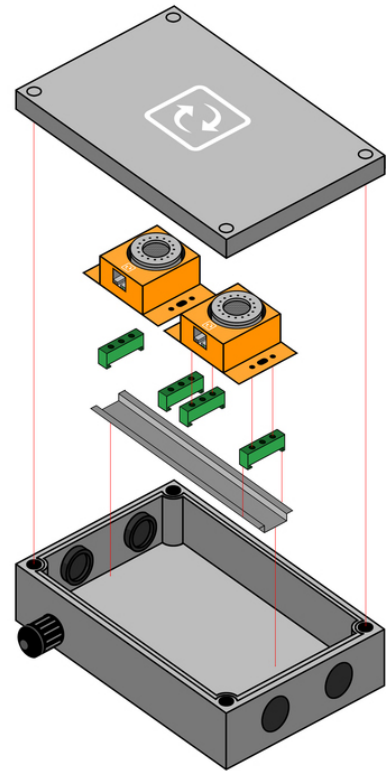

IP 65 Sensor Protection Box (AX-BOX-IP65)

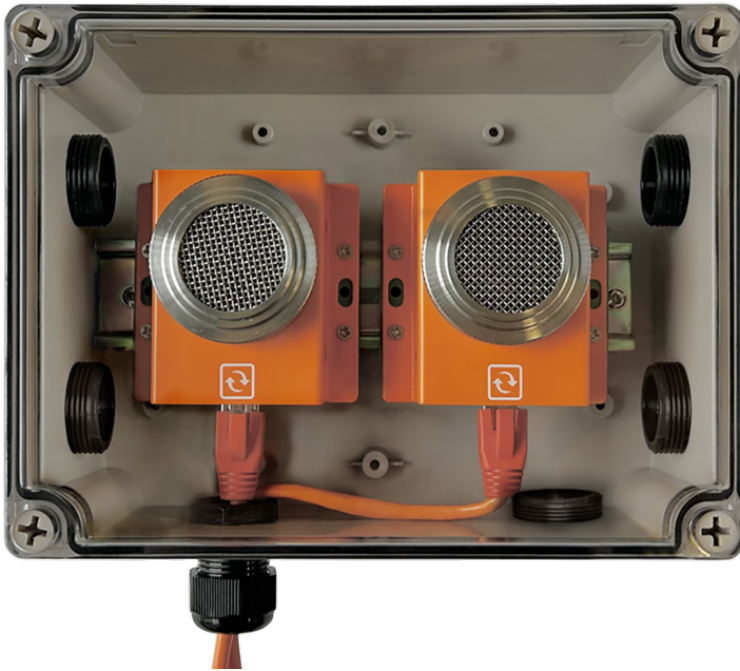

The Environmental Protection Enclosure IP Box is designed to safeguard sensors from outdoor environments. With sufficient airflow, this IP65 rated enclosure allows you to deploy any type of sensor outside, providing protection against weather conditions, falling debris, dust, oil and other non-corrosive materials.

Certification:

CE

Physical Specifications:

Product material	Polycarbonate
Enclosure	IP 65 rated enclosure
Dimensions	181mm (7.13") x 150mm (5.91") x 100mm (3.94")
Weight (sensor excluded)	622g (1.37 lbs.)