

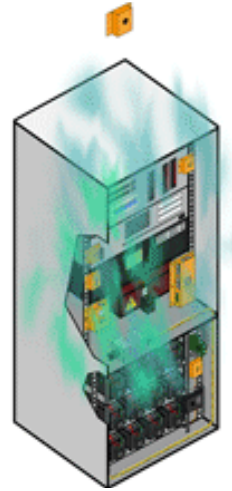

Nitrogen Dioxide (NO2) Gas Sensor (GAS-NO2)

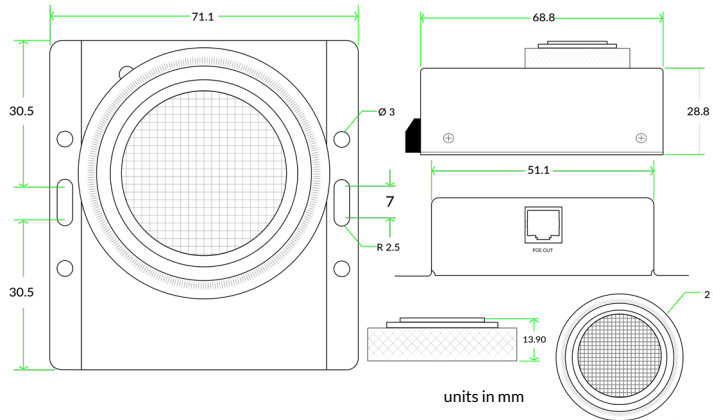

Digital sensor designed for monitoring and measuring the level of Nitrogen Dioxide (NO2) in the ambient air.

Sensor Metrics:

Measurement range	0-20 ppm
Maximum detection	250 ppm
Response time (T90)	≤ 30 seconds
Warm up time	10 minutes
Calibration frequency	up to 1 year
Life span	2 years
Detection technology	Electrochemical

Technical Specifications:

Powered and communicates with	Base Unit (BASE-XX) (required) Requires the optional BASE-FW-SSLS firmware add on for the Base Unit
Connectivity	RJ45 cable transmitting data & power from Base Unit to Sensor
Cable specification	RJ45 CAT 6/7 recommended Up to 100m (330ft) subject to cable quality & interference
Sensor power usage	216 mW

Environmental Specifications:

Operating temperature range	-20°C to +50°C (-4°F to +122°F)
Humidity (operating and storage)	15 - 90% rH (non-condensating)

Physical Specifications:

Sensor enclosure	Steel enclosure, industrial grade
Mounting option	OU rack, DIN rail, magnetic or wall mountable sensor
Dimensions	71.1mm (2.8") x 68.8mm (2.71") x 28.8 mm (1.13")
Weight	193g (0.43lbs)