

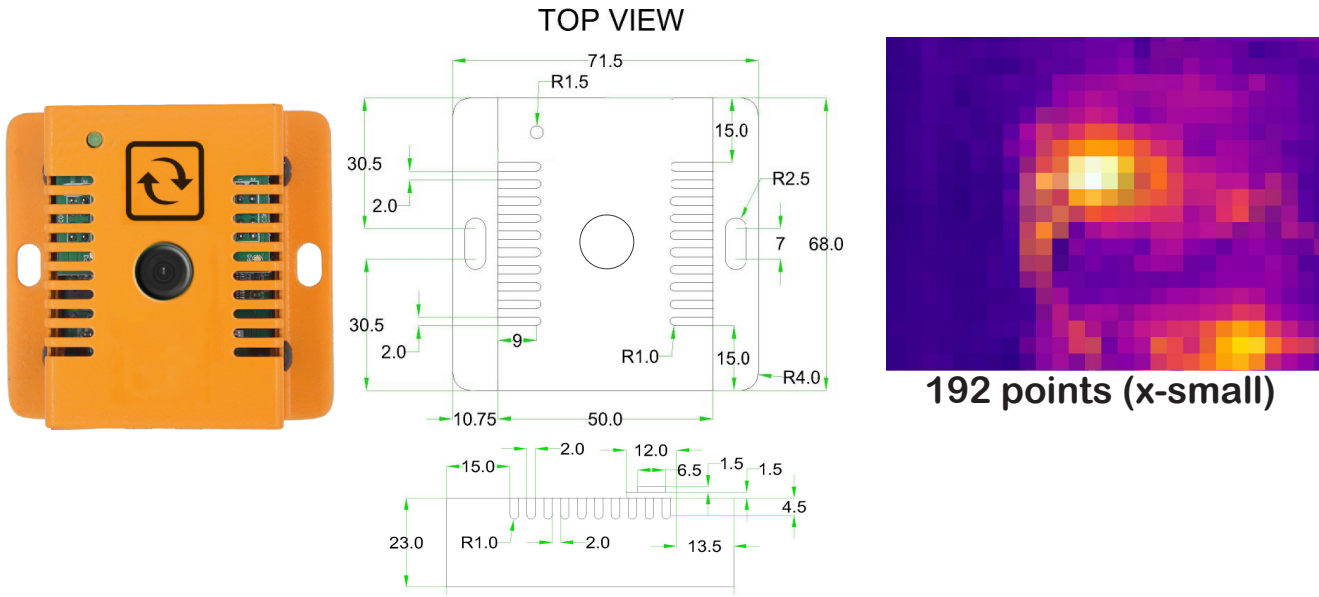

Thermal Image IR Sensor (ENV-THIMG-XS)



192 points (x-small)

General Description

A regular temperature sensor provides you with the temperature of the air surrounding the sensor. The thermal camera sensors provide you with the temperature of the objects & equipment it sees. The world's first SNMP & Modbus thermal camera sensor that tells you the temperature of what it actually sees. 192 temperature measurement points in one image, analysed every 2 seconds. Minimum and maximum temperature data is available to industrial and IT automation platforms via Modbus TCP or SNMP.

Key Features

- plugs into the base unit (BASE-WIRED)
- powered by the base unit (BASE-WIRED)
- can be OU rack, din rail, magnetic, or wall mounted
- reading in Celcius or Fahrenheit
- can detect object temperature from -40°C to 300°C
- up to 5 thermal camera sensors supported (by connecting to SensorHub)
- outputs maximum temperature per zone
- can add up to 4 zones

Technical Specifications

Power source	SensorGateway (BASE-WIRED)
Power usage	492 mW
Target temperature range	-40 °C to 300 °C (-40 °F to 572 °F)
Temperature accuracy	± 1.5°C / 34.7°F
Field of View (FoV)	110° horizontal(wide) 75° vertical
Resolution	16x12 pixels

Environmental and Physical Specification

Operating temperature range	-10°C to +85°C (14°F to 185°F)
Humidity (operating and storage)	< 90% rH (non-condensating)
Dimensions	71.5 mm (2.8") x 68 mm (2.7") x 23 mm (0.9")
Weight	0.112kg (0.25 lbs)