

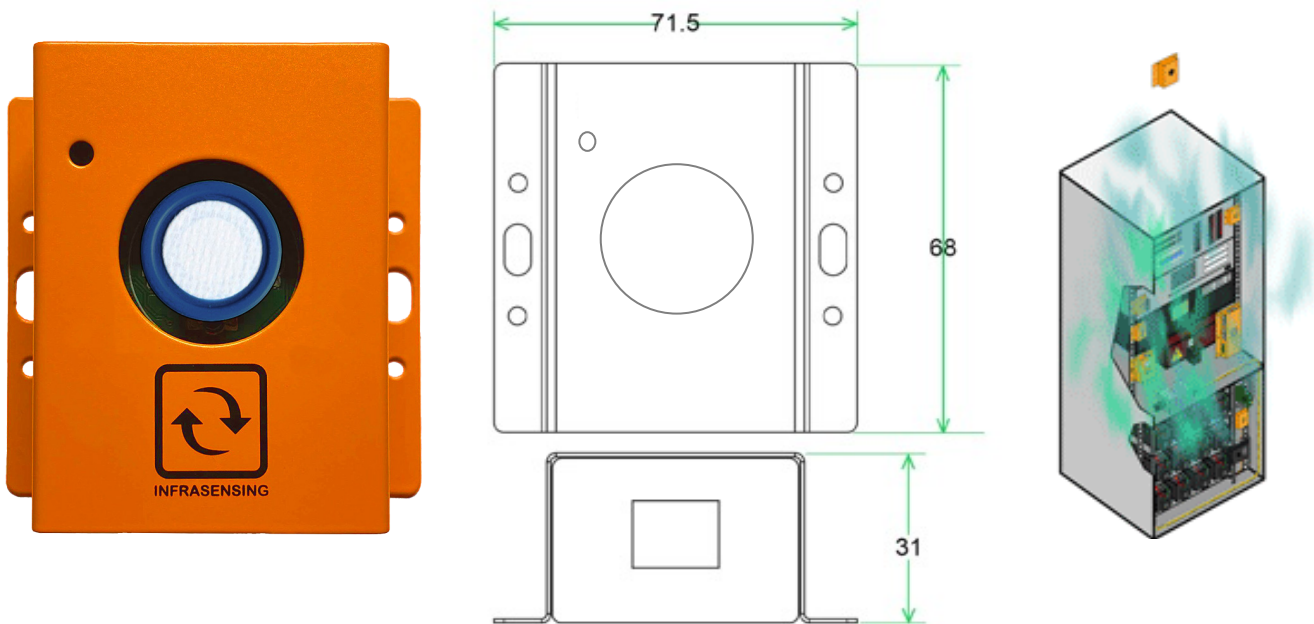

Chlorine (CL2) Gas Sensor (ENV-GAS-CL2)

Sensor Page

Store Page



General Description

Digital SNMP & Modbus TCP sensor designed for monitoring and measuring the level of Chlorine(CL2) in the ambient air.

Key Features

- plugs into the base unit (BASE-WIRED)
- powered by the base unit (BASE-WIRED)
- can be OU rack, din rail, magnetic, or wall mounted
- measures Chlorine in the air between 0-10 ppm (parts per million)
- maximum detection of 100 ppm
- alerts via SNMP Traps, email, SMS or voice calls

Technical Specifications

Power source	SensorGateway (BASE-WIRED)
Power usage	216 mW
Measurement range	0-10 ppm
Max detecting concentration	100 ppm
Response time	<60s
Lifetime	2 years

Environmental and Physical Specification

Operating temperature range	0°C to +70°C (32°F to +158°F)
Humidity (operating and storage)	< 90% rH (non-condensating)
Dimensions	71.5 mm (2.8") x 68 mm (2.7") x 31 mm (1.2")
Weight	0.13 kg (0.29 lbs)